



## 30" Acqualina Glass Wall-mount Range Hood

### Features:

- Stainless steel (highest grade AISI 304)
- Tempered glass panel
- Electronic, illuminated control panel
- 4 adjustable blower speeds
- 2x 20-watt halogen lights
- "Easy-Open" technology light fixtures
- Delayed shut-off
- Electronic reset
- 2x designer (dishwasher-safe) filters - standard
- Duct / ductless installation option - standard
- Automatic thermo protection
- Radio interference protection
- Quiet tangential motor
- Sound-absorbing motor chamber
- Noise level: 0.5 - 3.2 sones
- Power: 110-120 V / 60Hz / 4.0A / 940 CFM
- 6" round duct output
- ANSI/CSA/UL certified
- Made in Italy

### Three-Year Manufacturer's Warranty:

- 1-year full US standard
- + 2-year parts
- + Lifetime blower



Illuminated, multi-function  
electronic control panel



"Easy-Touch" technology  
halogen light fixtures



Designer filters - standard  
on this model

## 30" Acqualina Glass - Wall-mount

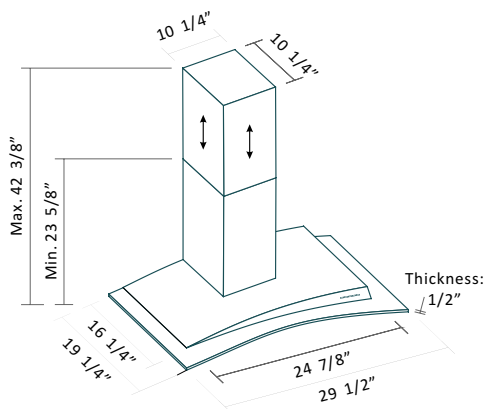

### Notes:

---

---

---

---